



New:
up to 1.500 mW/cm²

LED

LED Spot 100 High Power & LED powerdrive

UV LED flood lamp

Max. irradiation intensity: up to 1.500 mW/cm²

Wavelength: 365, 385, 395, 405 and 460 nm

Air cooled

System features

- Extremely long LED service life
- Available in different wavelengths
- Intelligent power control
- Controller for one, two or three LED Spot 100 available
- 100 mm x 100 mm Irradiation area

Advantages

- Reduction of maintenance costs
- Homogeneous irradiation of larger areas
- Suitable for temperature sensitive materials
- No warm-up phase
- No stand-by time
- Stackable for bigger areas

LED Spot 100 High Power & LED powerdrive

The **LED Spot** has been developed for all applications requiring **a highly intensive UV irradiance over a large area**. The LED assembly, as well as an electronic power control, guarantee high intensity and homogenous distribution of light. The recognition of LED-malfunction and a comprehensive monitoring function provide very high process stability. So, especially in fully automated production lines, repeatable results can be realised even in shortest cycle times.

The typical **service life of a LED is longer than 20.000 hours*****. The LED Spot 100 can be switched on and off as often as necessary. It does not require a warm-up or cooling phase.

The emitted wavelengths are available in 365/385/395/405/460 nm +/- 10 nm. This allows to adapt the LED head to the existing application.

The square light emitting aperture has a size of 100 mm x 100 mm. Depending on the required intensity/homogeneity it can be increased considerably by changing the distance to the substrate. For even bigger irradiation fields, several LED Spots 100 can be connected without gaps. An integrated fan provides adequate cooling even for continuous operation.



Applications

The LED Spot 100 controlled by LED **powerdrive** is appropriate for various applications, such as

- Bonding, fixing or encapsulating of components in the electronic, medical or optical sector
- Fluorescence stimulation for materials testing and picture processing
- High-intensity UV irradiation in the biological, chemical and pharmaceutical sector

LED Spot activation

The irradiation time can be optionally set between the ranges 0,01 - 99,99 sec. or 0,1 - 999,9 sec. or 1 - 9999 sec. Alternatively, continuous operation can be chosen.

The operating status and the actual temperatures of the LED segments as well as the irradiation times can be seen on the display at one glance. **The electrical LED power can be adjusted between 2 % and 100 % in 1 %-steps.**

The unit registers the LED operating hours as well as the units operating hours.

In summary, the following features characterize the LED **powerdrive** controller:

- Large and clear display with all relevant information
- Intelligent power control
- Temperature / error control of LED
- Shortest cycle time 0,01 s
- Up to three LED Spot 100's can be operated by one control system

Interfaces

The LED **powerdrive** controller has the following interfaces:

- Analog preselected power range 1V - 10V \triangleq 10% - 100%

- PLC inputs: LED on, LED enable/v
- PLC outputs: LED on, LED off, LED error, LED warning
- Dry contact with selectable function (cf. PLC outputs)
- Foot switch
- Release safety circuit (=LED enable)

Technical data

LED service life	> 20.000 hours***
adjustment range of timer	0,01 - 99,99 or 0,1 - 999,9 or 1 - 9999 or continuous operation
wavelengths in nm	365* 385* 395* 405* 460**
typical intensity in mW/cm ²	600 800 900 1000 1500
power supply LED powerdrive	90 V – 264 V, 47 Hz – 63 Hz
max. input current	2,8 A
irradiation area	100 x 100 mm
dimensions LED-head without connectors (HxWxD)	ca. 150 x 111 x 111 mm

* measured with Hönle UV meter and LED surface sensor, distance 0 mm

** measured with Hönle UV meter and VIS surface sensor, distance 0 mm

*** typical lifetime under specified operating conditions

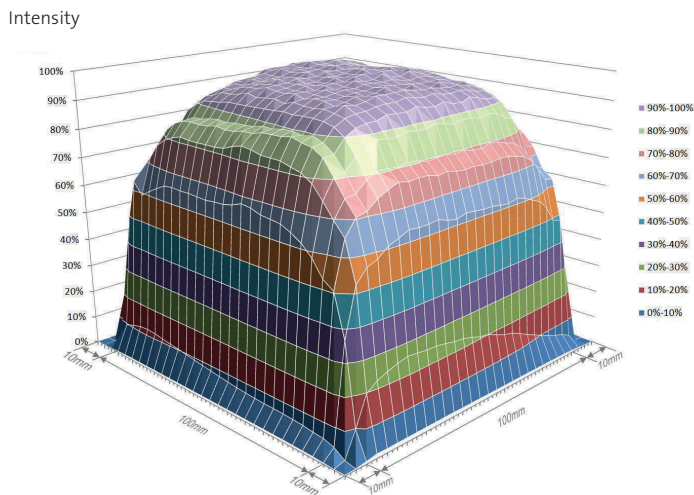

Intensity distribution LED Spot 100, distance 5 mm

Advantages of the LED technology

LEDs **do not emit IR radiation**. Even **temperature-sensitive materials** can be irradiated. The **different available spectra** guarantee safe and fast curing. As LEDs do not require a warm-up phase, LED heads can be switched on and off without any problems: **they are ready for immediate operation**.

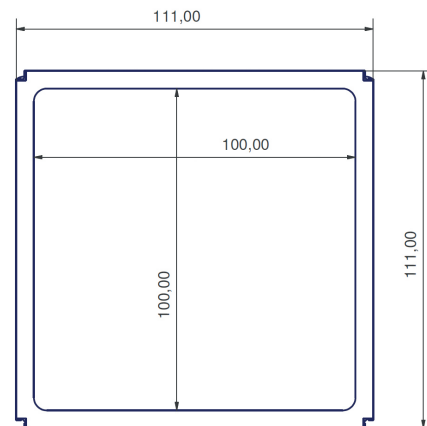
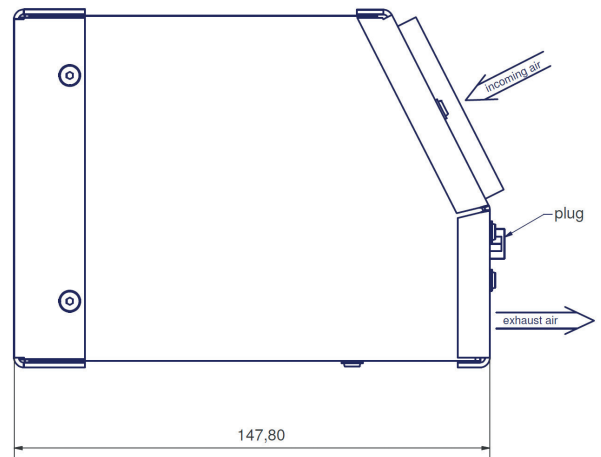

More Hönle LED-Units

watercooled types



LED Spot W

The LED Spot W allows an extremely high UV intensity output - and requires only a very small amount of space.



LED Powerline LC

Maximal length depends on application (length variable in 40 mm-steps). The LED Powerline LC is available in the wavelengths 365/385/ 395/405 nm.

aircooled types



LED Spot

The LED Spot operates only with air-cooling and is characterized by a highly intensive irradiation power.



Bluepoint LED eco

bluepoint LED eco has been developed for all applications requiring a most intensive punctiform UV irradiation.



LED Pen 2.0

The UV-Pen is a LED-technology based reliable point source with an output spectrum of 365 nm +/- 10 nm.



LED Power Pen 2.0

By using a unique lens-system this high-performance version of the LED Pen offers a focused UVA intensity of 10.000 mW/cm² (within 12 mm distance to the irradiation exit).

hönle group		Curing	Drying	Bonding	Potting	Measuring



Dr. Hönle AG UV Technology, Lochhamer Schlag 1, 82166 Gräfelfing/München, Germany
Phone: +49 89 85608-0, Fax: +49 89 85608-148. www.hoenle.de

Operating parameters depend on production characteristics and may differ from the foregoing information. We reserve the right to modify technical data. © Copyright Dr. Hönle AG. Updated 02/16.