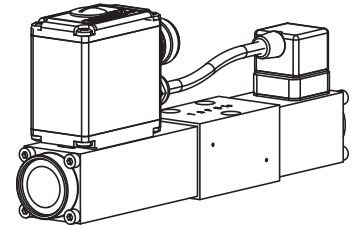

**Proportional directional control valve**

- **Integrated amplifier**
- **Integrated spool position control with LVDT**
- **Direct operated, not pressure compensated**
- $Q_{max} = 20 \text{ l/min}$
- $Q_N = 8 \text{ l/min}$
- $p_{max} = 315 \text{ bar}$

**NG4-Mini®**

**DESCRIPTION**

Direct operated proportional spool valve with integrated electronics in flange design NG4-Mini acc. to Wandfluh standard with 4 ports. The valve possesses an integrated positional control of the valve spool. This assures a minimal hysteresis and improved dynamic characteristics. Housing for electronics with protection class IP67 for harsh environment. The spool valve is designed acc. to the 5 chamber principle. The volume flow is adjusted by Wandfluh proportional solenoids (VDE standard 0580). Low pressure drop due to the body design and spool profiling. The spool is made of hardened steel. The body made of high grade hydraulic casting is painted. The solenoids are zinc coated and the housing for the electronics is made of aluminium.

**FUNCTION**

With the integrated spool position sensor (LVDT) the actual position of the spool is continuously recorded and made to follow the set-point value transmitted in an analogue manner. By means of this internal positional control, a minimal hysteresis and excellent dynamic characteristics are assured. With an increasing set-point value signal, the valve opening and therefore the volume flow increases and vice versa. Parameter setting and diagnosis with the free-of-charge software «PASO». Data are stored in a non volatile memory. Even after an electric power failure settings can easily be reproduced and transmitted.

**APPLICATION**

Proportional directional control valves with integrated electronics are highly suitable for demanding applications thanks to a high resolution, large volume flow, minimal hysteresis and very good dynamic characteristics. They are implemented in systems calling for good valve-to-valve reproducibility, easy installation, comfortable operation and high precision in industrial hydraulics as well as in mobile hydraulics for the smooth control of actuators. Application examples: pitch control of wind generators, forest and earth moving machines, machine tools and paper production machines with position controls, robotics and fan control.

**CONTENT**

GENERAL SPECIFICATIONS .....	1
TYPE CHARTS/ DESIGNATIONS OF SYMBOLS .....	2
HYDRAULIC SPECIFICATIONS .....	2
ELECTRICAL SPECIFICATIONS .....	2
START-UP .....	2
CONNECTOR WIRING DIAGRAM .....	2
CHARACTERISTICS .....	3
DIMENSIONS .....	4
PARTS LIST .....	4
ACCESSORIES (not incl. in the delivery) .....	4

**TYPE CODE**

	B	R	W	<input type="checkbox"/>	4	<input type="checkbox"/>	-	<input type="checkbox"/>	- 24	<input type="checkbox"/>	#	<input type="checkbox"/>
Interface												
With integrated electronics and position control												
Proportional directional valve												
Control mode acc. to table 1.10-70/2												
Number of control ports												
Designation of symbols acc. to table 1.10-70/2												
Nominal volume flow $Q_N$ :	4 l/min	<input type="checkbox"/>	4	<input type="checkbox"/>	8 l/min	<input type="checkbox"/>	8					
Standard nominal voltage $U_N$ :	24 VDC											
Hardware configuration:												
With analog signal (-10...+10 V factory set)	<input type="checkbox"/> A2											
With CANopen acc. to DSP-408	<input type="checkbox"/> C1											
With Profibus DP acc. to Fluid Power Technology	<input type="checkbox"/> P1											
Design-Index (Subject to change)												

**GENERAL SPECIFICATIONS**

Designation	4/3-way proportional valve with integrated electronics	Ambient temperature	-20...+65 °C (typical) <small>(The upper temperature limit is a guideline value for typical applications, in individual cases it may also be higher or lower. The electronics of the valve limit the power in case of a too high electronics temperature. More detailed information can be obtained from the operating instructions «DSV».)</small>
Nominal size	NG4-Mini acc. to Wandfluh standard	Mounting position	any, preferably horizontal
Construction	Direct operated spool valve	Fastening torque	$M_D = 5,5 \text{ Nm}$ (quality 8.8)
Operations	Proportional solenoid, wet pin push type, pressure tight	Weight	$m = 1,95 \text{ kg}$
Mounting	Flange, 3 fixing holes for socket head cap screws M5x40		
Connections	Threaded connection plates, multi-flange subplates, longitudinal stacking system		

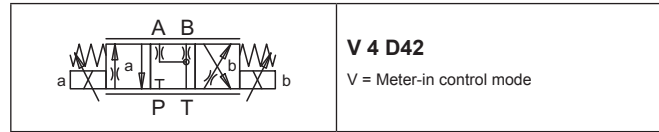
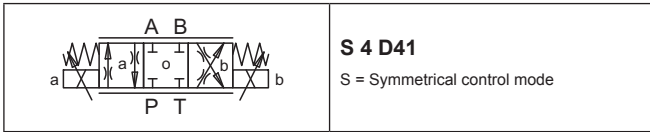
**TYPE CHARTS / DESIGNATIONS OF SYMBOLS**

**HYDRAULIC SPECIFICATIONS**

Fluid	Mineral oil, other fluid on request
Contamination efficiency	ISO 4406:1999, class 18/16/13 (Required filtration grade $\beta_{6...10} \geq 75$ ) refer to data sheet 1.0-50/2
Viscosity range	12 mm <sup>2</sup> /s...320 mm <sup>2</sup> /s
Fluid temperature	-20...+70 °C
Working pressure	$p_{max} = 315$ bar (connections P, A, B)
Tank pressure	$p_{max} = 160$ bar (connections T)
Nominal volume flow	$Q_N = 4$ l/min, 8 l/min
Max. volume flow	see characteristic
Leakage volume flow	on request
Hysteresis	< 0,4 %
Repeatability	< 0,4 %
Jump response	typically 25 ms from 10 to 90 %
Frequency response	see characteristics

**ELECTRICAL SPECIFICATIONS**

Protection class	IP 67 acc. to EN 60 529 with suitable connector and closed electronic housing
Supply voltage	24 VDC
Ramps	separate adjustment for up and down for each solenoid
Parameterisation Interface	via fieldbus or USB USB (Mini B) for parameterisation with «PASO» (under the closing screw of the housing cover, factory set parameters)

**Analog interface:**

Device receptacle (male)	M23, 12-poles
Mating connector	Plug (female), M23, 12-poles (not incl. in delivery)
Preset value signal:	Voltage / current selected with software

**Fieldbus interface:**

Device receptacle supply (male)	M12, 4-poles
Mating connector	Plug (female), M12, 4-poles (not incl. in delivery)
Device receptacle CANopen (male)	M12, 5-poles (acc. to DRP 303-1)
Mating connector	Plug (female), M12, 5-poles (not incl. in delivery)
Device receptacle Profibus (female)	M12, 5-poles, B-codiert (acc. to IEC 947-5-2)
Mating connector	Plug (male), M12, 5-poles, B-codet (not incl. in delivery)
Preset value signal:	Fieldbus

**NOTE!**

Detailed electrical characteristics and description of «DSV» electronics are shown on data sheet **1.13-75**.

**START-UP**

Normally there is no need to adjust settings by the customer. The connectors have to be wired according to the chapter «Connector wiring diagram».

Axis controllers will be supplied configured as amplifiers. Switching into controller mode and setting of the adjustments of the controller must be done by the customer using the set-up software (Serial interface.)

Additional information can be found on our website:  
**«www.wandfluh.com»**

Free-of-charge download of the «PASO»-software and the instruction manual for the «DSV» hydraulic valves as well as the operation instruction **CANopen** protocol with device profile DSP-408 for «DSV».

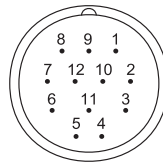
**CONNECTOR WIRING DIAGRAM**
**Analog interface:**
**Device receptacle (male) X1**

- 1 = Supply voltage +
- 2 = Supply voltage 0 VDC
- 3 = Stabilised output voltage
- 4 = Preset value voltage +
- 5 = Preset value voltage -
- 6 = Preset value current +
- 7 = Preset value current -
- 8 = Reserved for extensions
- 9 = Reserved for extensions
- 10 = Enable control (Digital input)
- 11 = Error signal (Digital output)
- 12 = Chassis

Preset value voltage (PIN 4/5) resp. current (PIN 6/7) are selected with set-up and diagnosis software.  
 Factory setting: Voltage (-10...+10 V), (PIN 4/5)

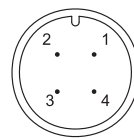
**Fieldbus interface:**
**Device receptacle supply (male) X1**

**MAIN**

- 1 = Supply voltage +
- 2 = Reserved for extensions
- 3 = Supply voltage 0 VDC
- 4 = Chassis

**Device receptacle CANopen (male) X3**

**CAN**

- 1 = not connected
- 2 = not connected
- 3 = CAN Gnd
- 4 = CAN High
- 5 = CAN Low

**Device receptacle Profibus (female) X3**

**PROFIBUS**

- 1 = VP
- 2 = Rx / Tx - N
- 3 = DGND
- 4 = Rx / Tx - P
- 5 = Shield

**Parameterisation interface (USB, Mini B) X2**

Under the closing screw of the housing cover

**NOTE!**

The mating connector and the cable to adjust the settings are not part of the delivery. To order the cable, look up the article no. in the chapter «Accessories».

**CHARACTERISTICS** Oil viscosity  $\nu = 30 \text{ mm}^2/\text{s}$ 

$Q = f(p)$  Volume flow pressure characteristics  
 [Type: S4D41-08]  $S = 100\%$

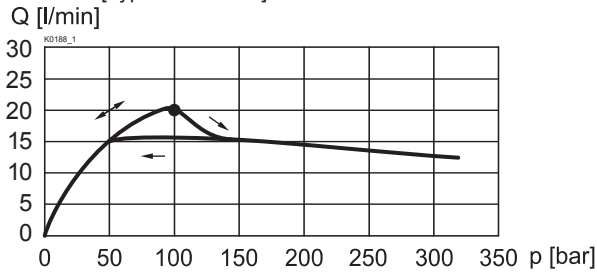

$Q = f(p)$  Volume flow pressure characteristics  
 [Type: S4D41-04]  $S = 100\%$

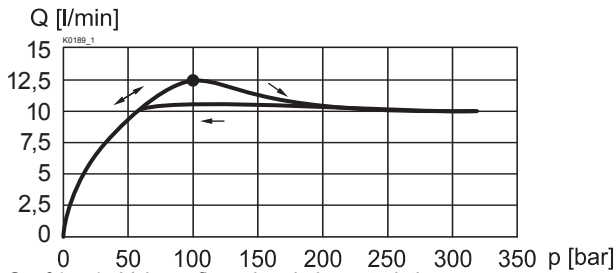

$Q = f(s, x)$  Volume flow-signal-characteristics ( $\Delta p = 10 \text{ bar}$ )  
 [Type: S4D41]  
 (s corresponds to preset value signal and x corresponds to spool stroke)

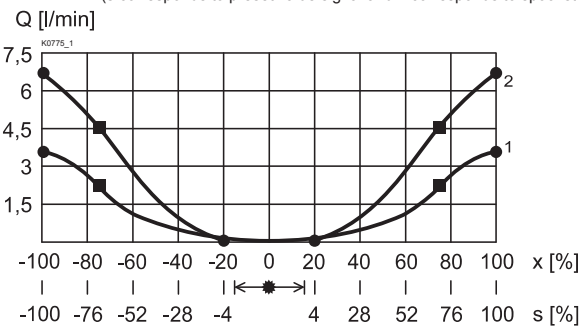

**Factory settings:**

- = Deadband: Both solenoids switched off with command signal  $-2\% \dots +2\%$
- = Opening point: at command signal  $\pm 4\%$
- = Flow at  $\Delta p = 10 \text{ bar}$  over 2 metering edges at command signal  $\pm 70\%$   
 4,5 l/min for  $Q_N = 8 \text{ l/min}$   
 2,1 l/min for  $Q_N = 4 \text{ l/min}$

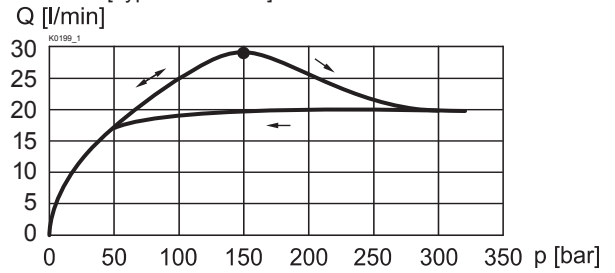
$Q = f(p)$  Volume flow pressure characteristics  
 [Type: V4D42-08]  $S = 100\%$

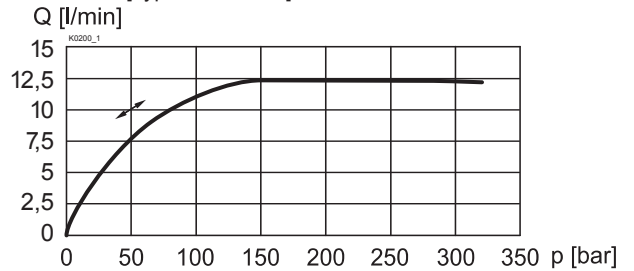

$Q = f(p)$  Volume flow pressure characteristics  
 [Type: V4D42-04]  $S = 100\%$

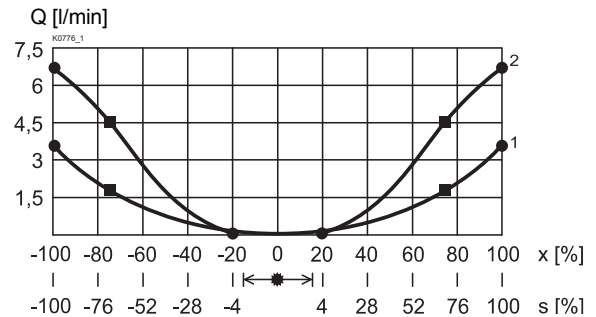

$Q = f(s, x)$  Volume flow-signal-characteristics ( $\Delta p = 10 \text{ bar}$ )  
 [Type: V4D42]  
 (s corresponds to preset value signal and x corresponds to spool stroke)

**Factory settings:**

- = Deadband: Both solenoids switched off with command signal  $-2\% \dots +2\%$
- = Opening point: at command signal  $\pm 4\%$
- = Flow at  $\Delta p = 10 \text{ bar}$  over 2 metering edges at command signal  $\pm 70\%$   
 4,5 l/min for  $Q_N = 8 \text{ l/min}$   
 1,9 l/min for  $Q_N = 4 \text{ l/min}$

**Legend:** 1:  $Q_N = 4 \text{ l/min}$   
 2:  $Q_N = 8 \text{ l/min}$

Frequency response [all types] ( $\Delta p = 10 \text{ bar}$ ,  $P_T < 1 \text{ bar}$ )

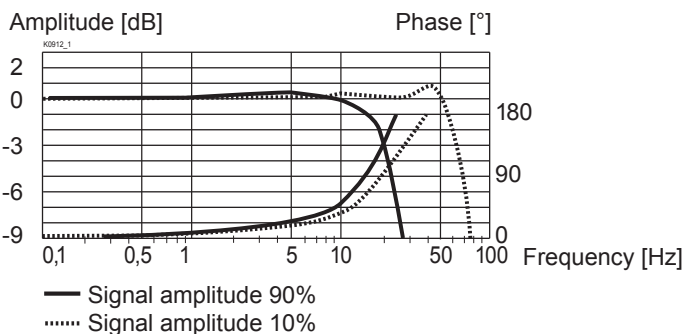
**NOTE!**

All values measured over 2 metering edges, A and B ports linked.

**DIMENSIONS**

With analog interface

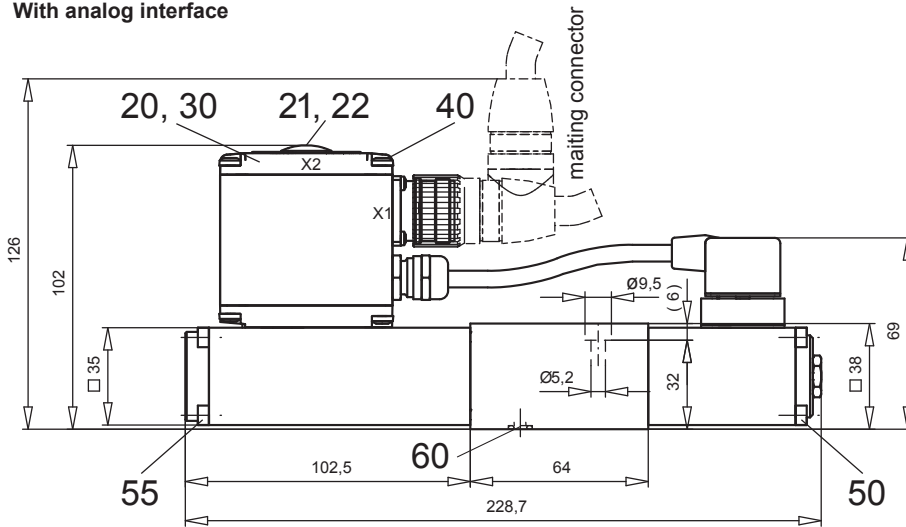

With fieldbus interface

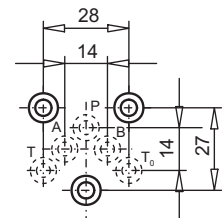
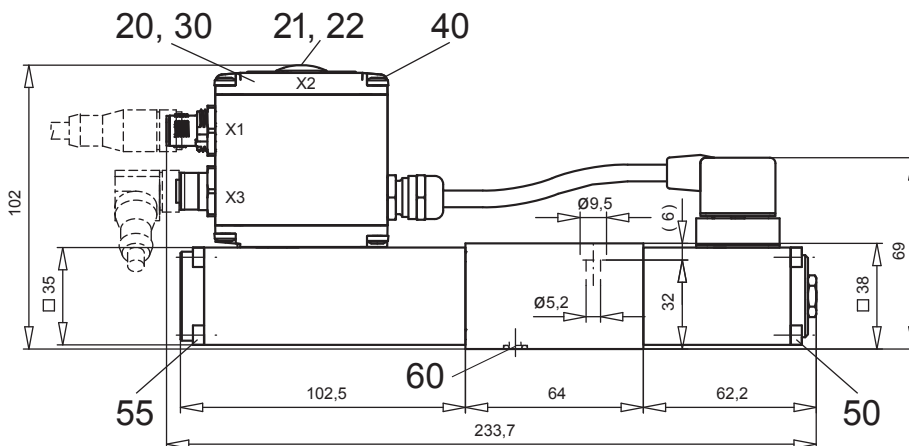
**NOTE!**

The cable connector is not part of the delivery. The dimensions refer to those of the cable connector in the chapter «Accessories».

**PARTS LIST**

Position	Article	Description
20	062.0102	Cover
21	223.1317	Dummy plug M16x1,5
22	160.6131	O-ring ID 13,00x1,5
30	072.0021	Gasket 33x2x59,9x2
40	208.0100	Socket head cap screw M4x10
50	246.1161	Socket head cap screw M4x60 DIN 912
55	246.1191	Socket head cap screw M4x100 DIN 912
60	160.2052	O-ring ID 5,28x1,78

**ACCESSORIES**

- Set-up software see start-up
- Cable to adjust the settings through interface USB article no. 219.2896  
(from plug type A to Mini B, 3m)
- Cable connector for analog interface: article no. 219.2330  
– straight, soldering contact article no. 219.2331  
– 90°, soldering contact  
Recommended cable size:  
– Outer diameter 9...10,5 mm  
– Single wire max. 1 mm<sup>2</sup>  
– Recommended wire size:  
0...25 m = 0,75 mm<sup>2</sup> (AWG18)  
25...50 m = 1 mm<sup>2</sup> (AWG17)

Technical explanation see data sheet 1.0-100