

60-TON-S/D HYDRAULIC

INTRODUCTION

This portable compressor is designed for the installation of electrical compression fittings either in the shop or in the field. The compressor develops 60 tons of force at 10,200 psi (70.2MPa) operating pressure.

The compressor can be operated in any position. To operate in the air, remove ground stand and suspend press from bail hook.

PUMP REQUIREMENTS

Any pump with a fluid reservoir capacity greater than 50 cubic inches and a relief valve setting between 10,000 and 10,400 psi may be used with this compressor.

HYDRAULIC LINES

Hydraulic lines rated for a minimum of 10,000 psi working pressure must be used regardless of mode of operation (Single or Double Acting).

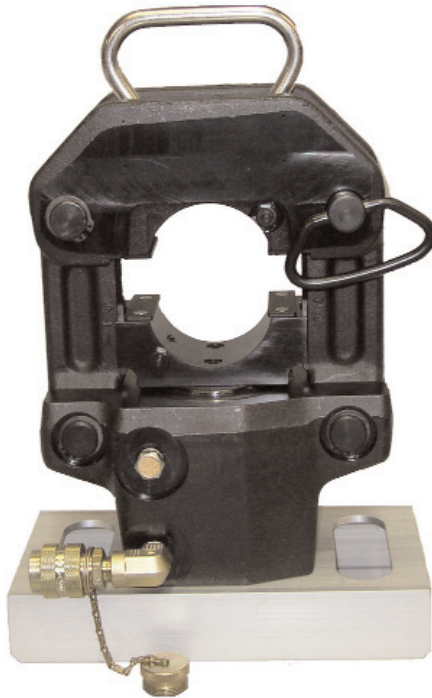

COMPRESSOR SPECIFICATIONS

Rated Force	60 Tons (62.8 actual)
Stroke (with dies)	1.31 inches
Operating Pressure	10,000 psi
Type	Single/Double Acting
Crimping Capacity	Stranded code cable, splices & terminals: 250-2000 mcm aluminum 300-2000 mcm copper

Dimensions (with ground stand)

Length.....	8.50 inches
Width	15.25 inches
Height	19.75 inches
Weight	76 lbs. (34.5 kg)
Oil	Petroleum based fluid, 180 SSU minimum at 100 Degree F 50 SSU at 210 Degrees F min for best performance.

IMPORTANT SAFETY INFORMATION



This is the safety alert symbol.

It is used to alert you to potential personal injury hazards. Obey all safety messages that follow this symbol to avoid possible injury or death



DANGER

Denotes an imminently hazardous situation which, if not avoided, will result in death or serious injury.



WARNING

Denotes a potentially hazardous situation which, if not avoided, could result in death or serious injury.



CAUTION

Denotes a potentially hazardous situation which, if not avoided, may result in minor or moderate injury.

CAUTION

Caution used without the safety alert symbol indicates a potentially hazardous situation which, if not avoided, may result in property damage.

IMPORTANT

Denotes an operating or service procedure or condition considered essential for expedient and efficient operation and service.



WARNING To help prevent personal injury,



- Always wear eye protection whenever operating hydraulic equipment.



- Always wear hearing protection as required.

- Operation, repair, or maintenance of hydraulic equipment should be performed by a qualified person who understands the proper function of hydraulic equipment per local directives and standards.
- Hydraulic equipment must be assembled correctly and then checked for proper function before use. Use hydraulic components of the same hydraulic pressure ratings. An appropriate hydraulic pressure gauge is recommended to monitor pressure.
- Before operating compressor, make sure pull pin assembly is fully engaged and die haves are properly installed.



- Never place your hands or other body parts near a hydraulic fluid leak. Never use your hands or other body parts to check for a possible leak.

High pressure fluid can be injected under your skin causing serious injury and/or infection.



- Exercise caution to avoid the risk of fire. An incomplete crimp can cause a fire. Use proper die, connector and cable. Improper combinations can result in an incomplete crimp.



- This tool is not insulated. When using this unit near energized electrical lines, use proper personal protective equipment.



CAUTION

- This tool is designed to operate at 10,200 psi. Lower operating pressure will fail to develop the full tonnage required. Higher iterating pressure could cause structural failure and injury to users.
- Do not operate without dies.

IMPORTANT

- Properly dispose of all fluids, components, and assemblies at the end of their useful life.
- Hydraulic fluid should be compatible with all hydraulic components.



WARNING



It is the operators responsibility to read and understand the following safety statements,

- Only qualified operators should install, operate, adjust, maintain, clean, repair, or transport this machinery.
- Inspect tool before use. Replace any worn or damaged parts. Failure to observe these warnings can result in severe injury or death.



WARNING



Keep hands away from connector to be crimped.

OPERATING INSTRUCTIONS

! WARNING DO NOT OPERATE THE COMPRESSOR WITHOUT DIES.

OPERATING MODES

Through a special piston design, the compressor can be operated in either **single acting** (spring return) or **double action** (hydraulic return) mode. Conversion from single acting to double acting can be accomplished by simply removing the vent plug from the upper (return port, substituting a quick coupler and utilizing a 4-way control valve at the pump.

SINGLE ACTING

In the single acting mode, the compressor is equipped with one quick coupler installed in the lower (advance) port and a vent plug in the upper (return) port.

One high pressure hydraulic line connects the compressor to the pump and serves as both inlet and return. The pump used with a single acting compressor must be equipped with a two (2) or three (3) way control valve.

SINGLE ACTING ADVANCE

High pressure hydraulic fluid from the pump enters the compressor through the lower (advance) port and forces the piston up, crimping the compression fitting. Air trapped above the piston is exhausted through the vent.

SINGLE ACTING RETURN

Hydraulic pressure from the pump is released and the piston is returned to its at-rest position by a return spring built into the compressor. Hydraulic fluid is returned to the pump reservoir through the same line used to advance the compressor

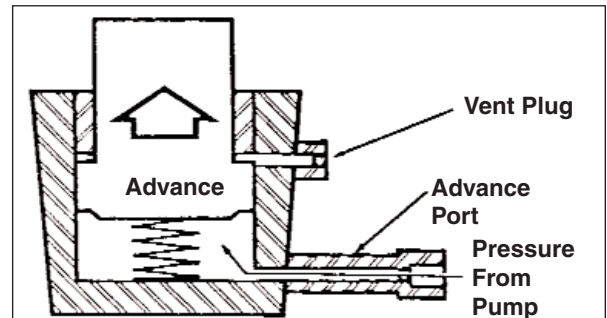

SINGLE ACTING ADVANCE OPERATION

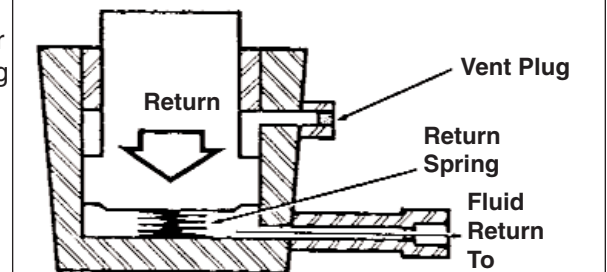

SINGLE ACTING RETURN OPERATION

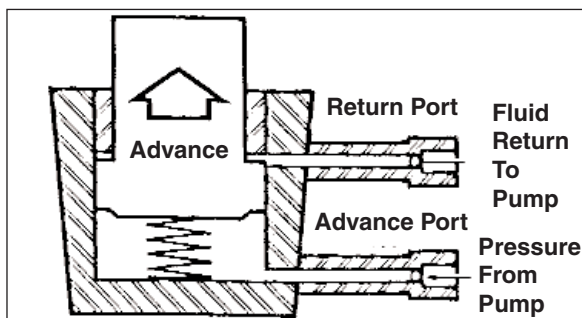

DOUBLE ACTING ADVANCE OPERATION

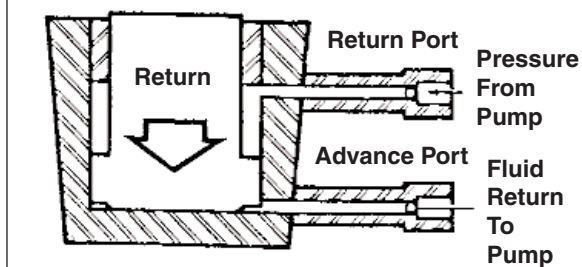

DOUBLE ACTING RETURN OPERATION

DOUBLE ACTING

In double acting operation pressurized hydraulic fluid is used to advance and return the piston resulting in faster cycle times than in single acting operation. In the double acting mode, the compressor is equipped with quick couplers installed in both the lower (advance) port and the upper (return) port. The high pressure hydraulic lines connect the compressor to the pump. The pump used with a double acting compressor must be equipped with a 4-way control valve.

DOUBLE ACTING ADVANCE

As in the single acting mode, high pressure hydraulic fluid from the pump enters the compressor through the lower (advance) port and forces the piston up, crimping the compression fitting. Hydraulic fluid above the piston is returned to the pump reservoir through the upper (return) port.

DOUBLE ACTING RETURN

High pressure hydraulic fluid from the pump enters the compressor through the upper (return) port and forces the piston down to its at-rest position. Hydraulic fluid below the piston is returned to the pump reservoir through the lower (advance) port of the compressor

OPERATING INSTRUCTIONS

Single Acting Set-Up

Connect one hydraulic line from the lower (advance) port of the compressor to a hydraulic pump equipped with a 2 or 3-way valve. Install vent plug in the upper (return) port

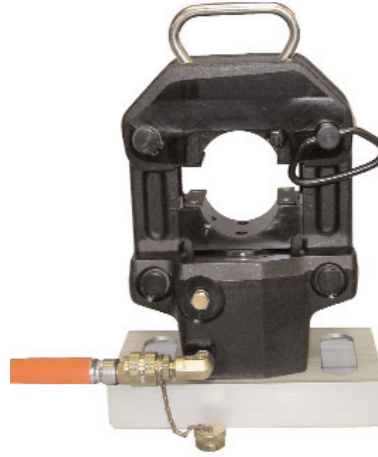

Single Acting Set-Up

Double Acting Set-Up

Connect two hydraulic lines from the compressor to hydraulic pump equipped with a 4-way valve. The advance line is connected to the lower (advance) port of the compressor and the return line is connected to the upper (return) port of the compressor.

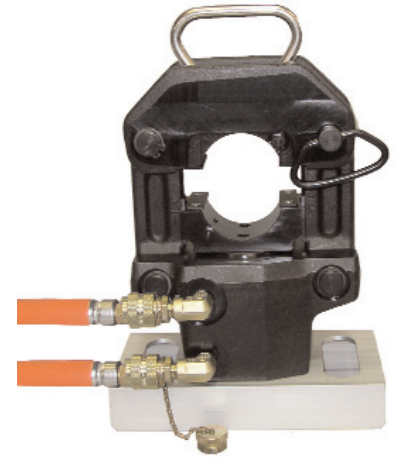

Double Acting Set-Up

Quick Coupler Connection

1. Remove dust covers from couplers.
2. Push male and female halves together at each connection and spin the threaded sleeve of the female half securely onto the threaded portion of the male half. The mating half of Quick-coupler supplied with compressor is Power Team Part No 25599

Note: With connections properly made, ball check valves in both halves of coupler are open to permit free flow of oil in either direction.

Installing Die Set

1. Select proper die set
2. Push die stop button and slide die half in place
3. Release die stop button and check that die half is securely locked in place.
4. Install remaining die half in same manner.

Making Compression

1. Withdraw pull pin until pin locks in open position and open compressor
2. Place accessory to be compressed on lower die half
3. Close top of compressor and push pin all the way in until detent is felt
4. Activate pump to close dies. When dies meet compression is complete
5. Shift pump valve to retract lower die. In single acting operation the piston is retracted by the return spring built into the compressor. In double acting operation, the piston is retracted by hydraulic pressure from the pump

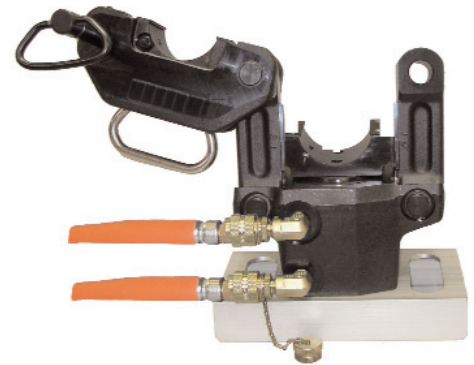

**60 Ton Compression Tool
Open Position**

Operate compressor only with top support closed and pull pin securely in place

Compatible Hydraulic Fluids:

The use of Amoco Rykon MV oil is recommended. Compatible fluids include:

Mobil DTE 13 Mobil ATF 220 Shell Tellus 32 Arco Dexron III Citgo AW32 Citgo Dexron III

Other fluids also may be used if they meet or exceed the following specifications:

Viscosity: 180 SSU at 100 degree F.

Flash Point: 350 degree F Pour Point: -50 degree F

MAINTENANCE

Note: Establish a regular maintenance program to prevent service problems.

1. Clean and inspect compressor after every use.
2. Lubricate moving parts monthly or after every 25 hours of use.
3. Check that pump relief valve pressure is set between 10,000 and 10,400 psi.
4. Check oil level in pump reservoir. Add oil as needed.

NOTE: A slight weeping of oil from the ram and pump seals is normal and required to keep moving parts lubricated. Excessive leakage indicates a need for seal replacement.

Side Bar, Piston Relief and Seal Replacements

Maintenance and repairs of this type should be performed by properly trained personnel in repair shops under clean conditions. In addition to all parts shown on the keyed parts lists, 3-7132 (side bar kit), 3-7133 (piston relief kit) and 3-6701 (seal kit) are available from the factory or an authorized service center.

Bleeding Compression Tool

Install dies in compression tool. Attach hose(s) from pump to compression tool. Lay compression tool on its side with quick-coupler(s) facing straight up. Position pump above the compression tool. Advance and retract the piston three times. By bleeding the compression tool with this method, air trapped in the compression tool will be transferred to the pump reservoir.

TROUBLESHOOTING

Dies Will Not Close

1. Test compressor with substitute pump to determine if problem is in pump or compressor.
2. Check die number to make certain proper size die is being used for accessory being compressed.
3. Check that pump relief valve pressure is set between 10,000 and 10,400 psi.
4. Check for insufficient oil level in pump reservoir

Lower Die Will Not Retract or Retracts Erratically (Single Acting Operation)

1. Check that quick couplers are securely tightened. If male and female halves are not securely tightened, the ball

check valves in the couplers are not forced completely open. In single acting operation the advance pressure from the pump can force oil past these partially open valves, but the force of the piston return springs is not sufficient to force oil back past them to the pump. If this is the case it may be necessary to use pliers or a wrench to close the couplers.

2. Weak or broken return spring.
3. Air in system.
4. Check for excessive oil level in pump reservoir.

Lower Die Will Not Retract (Double Acting Operation)

1. In double acting operation check that the pump control valve is operating properly; delivering full pressure to the return port of the compressor (1,800 to 2,500 psi)

Die Will Not Lock Into Position

1. Disassemble, clean and lubricate die retaining unit

Oil Leaking From Vent Plug (Single Acting Operation)

1. Replace seals. See Parts List

Oil Leaking From Piston Seal

1. Replace seals. See Parts List

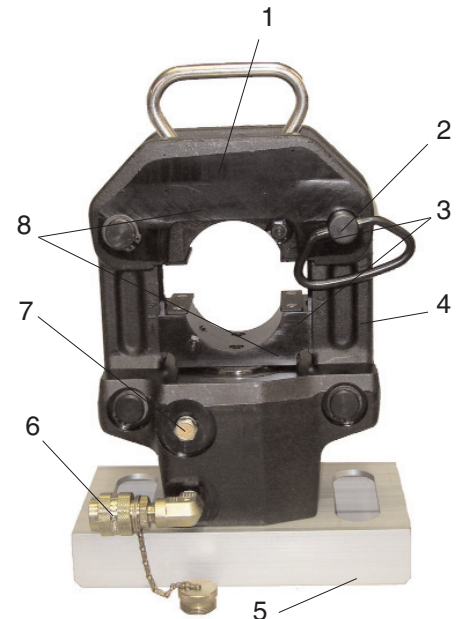

Illustration

1. Top Die Support Assembly
2. Pull Pin Assembly
3. Die Holders
4. Side Bar
5. Ground Stand
6. Coupler, Female (Advance Port)
7. Vent (Retract Port)
8. Die Stop Buttons

PARTS LIST

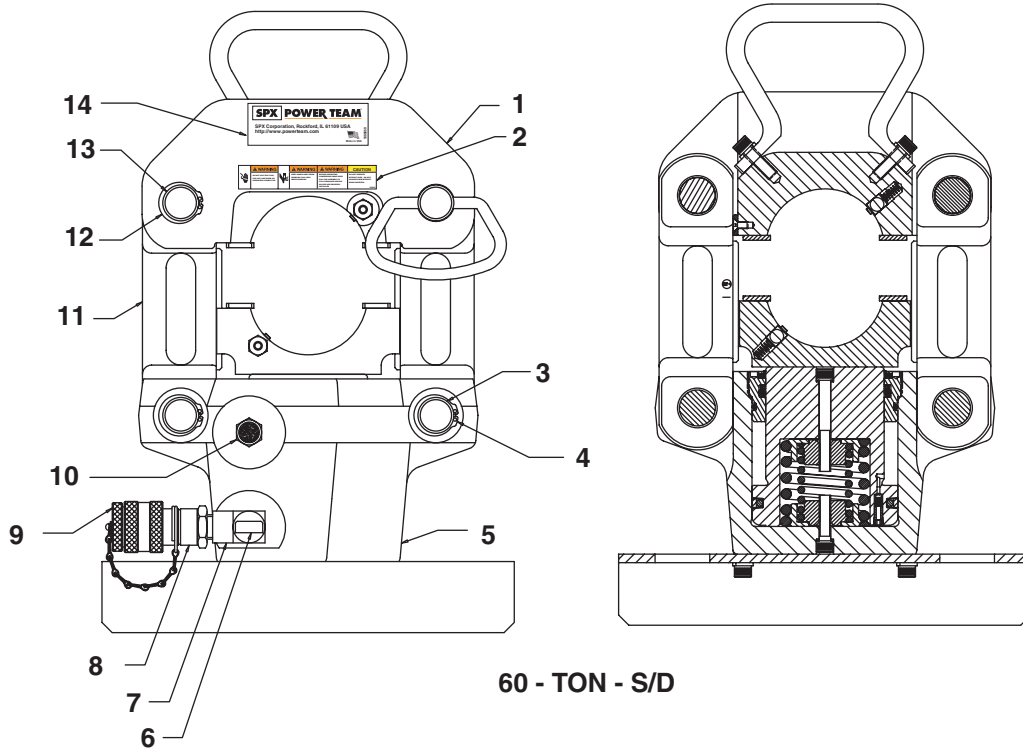

Item No.	Part No.	No. Req'd	Description
1	3-7202	1	Top Support Assembly
2	1000060	1	Decal, (Warning)
3	3-6512	2	Pin, Bottom Retained 60 Ton
4	5-3009	4	Ring, Retaining
5	3-8693	1	Base Assembly
6	3-7342	1	Decal
7	10621	1	Fitting, (Elbow 90 degree 3/8 NPTF)
8	9796	1	Coupler, Female (3/8" NPTF)
9	9797	1	Plug, Dust

Item No.	Part No.	No. Req'd	Description
10	5-3119	1	Breather Vent
11	3-6514	2	Side Bar, Machined 60 Ton
12	5-3009	2	Ring, Retaining
13	3-6513	1	Pin, Top Retained 60 Ton
14	1000056	1	Decal, (Tradename Power Team)
Item not shown			
	3-2106-OR9	1	Case, Carrying

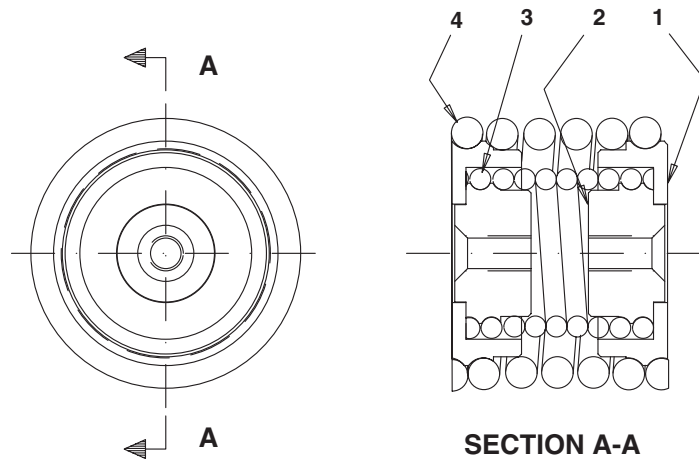

SPRING ASSEMBLY 3-3574

Item No.	Part No.	No. Req'd	Description
1	3-3591	1	Retainer, Outer Spring
2	3-3592	1	Retainer, Inner Spring

Item No.	Part No.	No. Req'd	Description
3	3-3594	1	Spring, Inner Tension
4	3-3593	1	Spring, Outer Tension

PARTS LIST

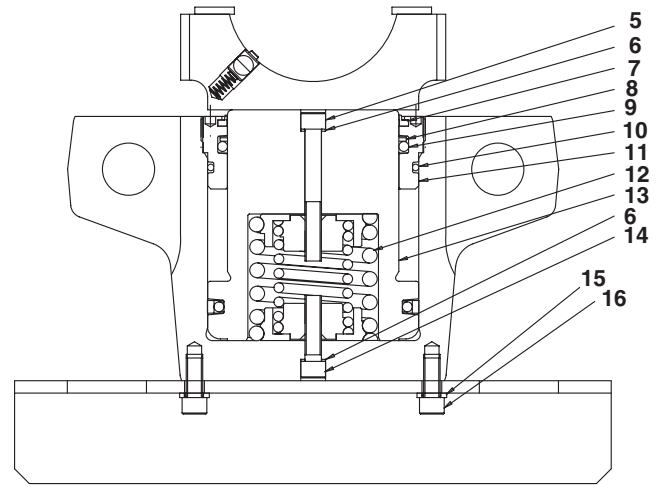
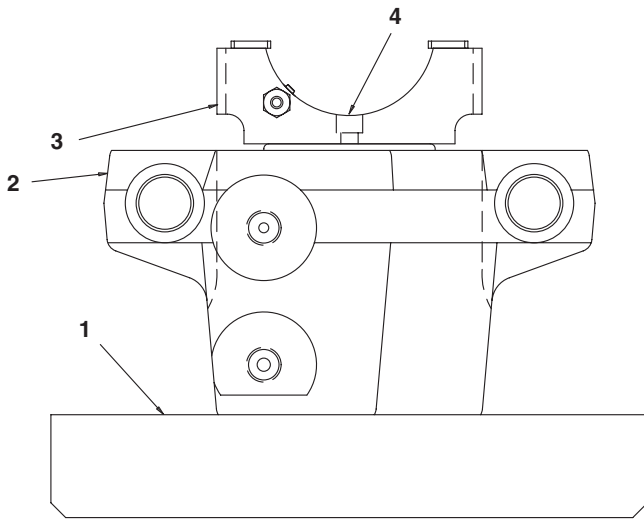

SECTION VIEW

BASE ASSEMBLY 3-8693

Item No.	Part No.	No. Req'd	Description
1	3-6509	1	Stand
2	3-6498	1	Base
3	3-6502	1	Die Holder Assembly
4	5-0225	2	Screw
5	251968	1	Screw
6	3-6796	2	Washer
7	16311	1	Wiper
8	5-3004	1	Ring, Back-Up

Item No.	Part No.	No. Req'd	Description
9	5-3006	1	O-Ring
10	211019	1	O-Ring
11	3-6501	1	Gland
12	3-3574	1	Spring Assembly
13	3-6691	1	Piston Assembly
14	5-0228	1	Screw
15	10246	4	Lockwasher
16	5-0226	4	Screw

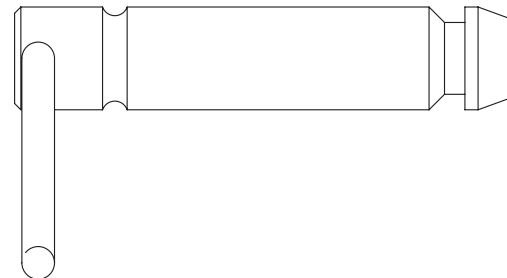
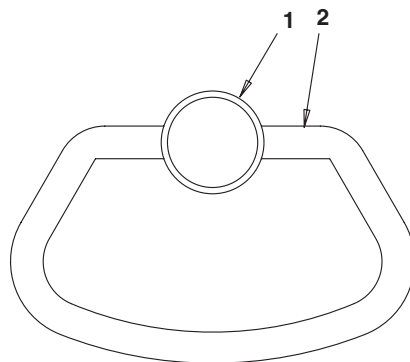

PIN ASSEMBLY 3-6510

Item No.	Part No.	No. Req'd	Description
1	3-6511	1	Pull Pin

Item No.	Part No.	No. Req'd	Description
2	3-6831	1	Handle

PARTS LIST

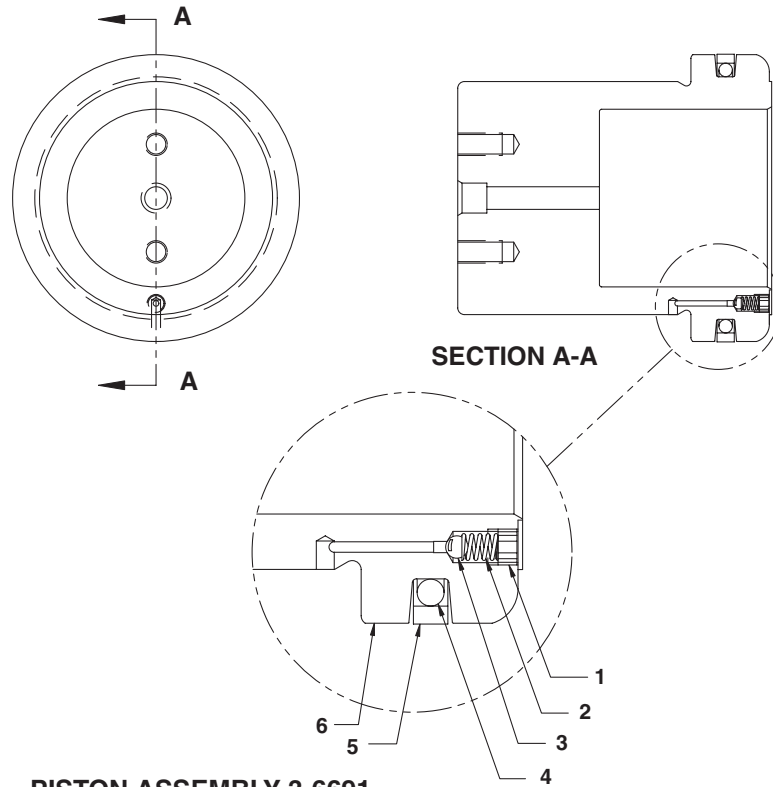

PISTON ASSEMBLY 3-6691

Item No.	Part No.	No. Req'd	Description
----------	----------	-----------	-------------

1	5-2062	1	Screw, Set (1/4-28 x 1/8)
2	5-3041	1	Spring, Compression
3	10419	1	Ball, 5/32" Dia. Steel

Item No.	Part No.	No. Req'd	Description
----------	----------	-----------	-------------

4	11768	1	O-Ring
5	5-3003	1	Seal
6	3-6500	1	Piston

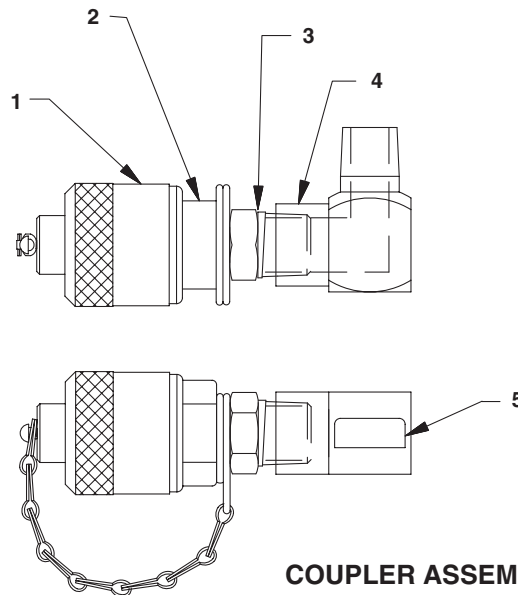

COUPLER ASSEMBLY 3-9965

Item No.	Part No.	No. Req'd	Description
----------	----------	-----------	-------------

1	9799	1	Cap, Dust
2	25599	1	Coupler, Hose Half
3	10673	1	Fitting, 3/8" NPTF

Item No.	Part No.	No. Req'd	Description
----------	----------	-----------	-------------

4	10621	1	Fitting, 3/8" NPTF
5	3-7343	1	Decal, (Retract)

PARTS LIST

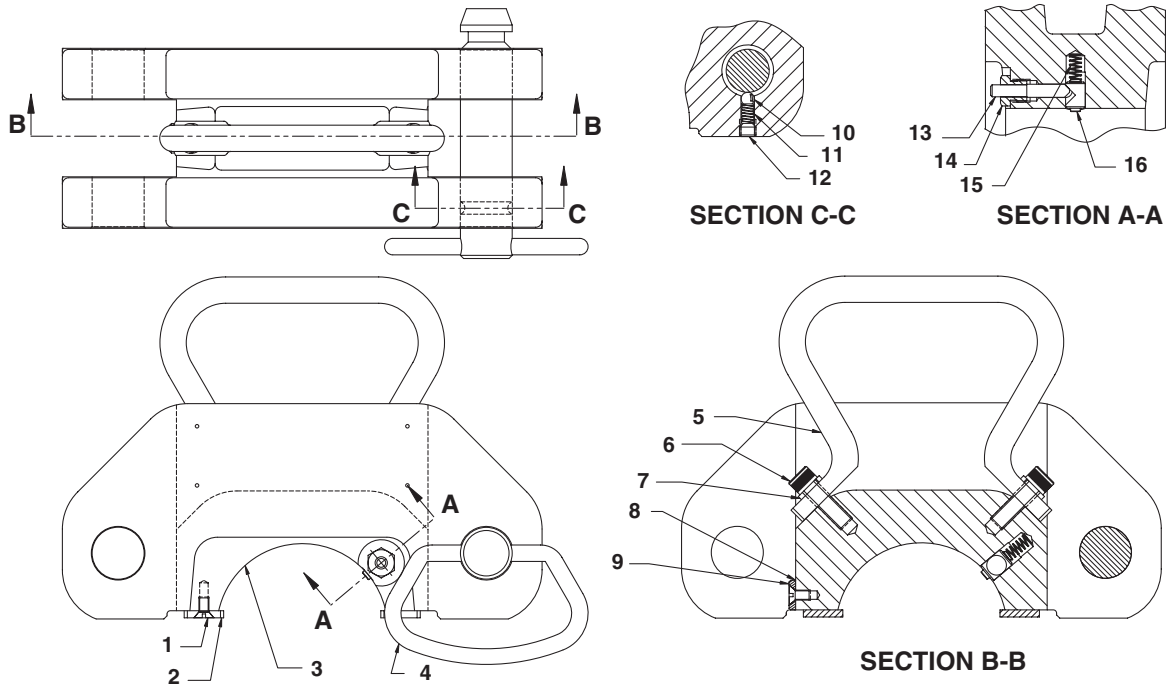

TOP SUPPORT ASSEMBLY 3-7202

Item No.	Part No.	No. Req'd	Description
1	5-1041	5	Screw, Flat Hd. (#10-32 x 3/8)
2	3-6689	2	Retainer, Die
3	3-7203	1	Support, Top
4	3-6510	1	Assembly, Pull Pin
5	3-6492	1	Handle, Top
6	210857	2	Screw, Soc.Hd. (5/16-24 x 1)
7	10246	2	Washer, Lock
8	5-3140	AS REQ'D	Washer, Shim
9	3-6688	1	Washer, Stop

Item No.	Part No.	No. Req'd	Description
10	10375	1	Ball, 1/4" Dia. Steel
11	5-3000	1	Spring, Compression
12	5-0659	1	Screw, Set (5/16-24 x 1/4)
13	3-6494	1	Rod, Push
14	3-6495	1	Screw, Stop
15	5-3001	1	Spring, Compression
16	3-6493	1	Plunger, Die